

LOC	DIST	REVISIONS			
HM	00	REV	DATE	BY	APPD
		A	NSD07-041	13MAY2007	JM SH
		B	ECO-07-015502	05JUL2007	JM SH
		C	REV: ECO-08-019881	14AUG2008	GG DC

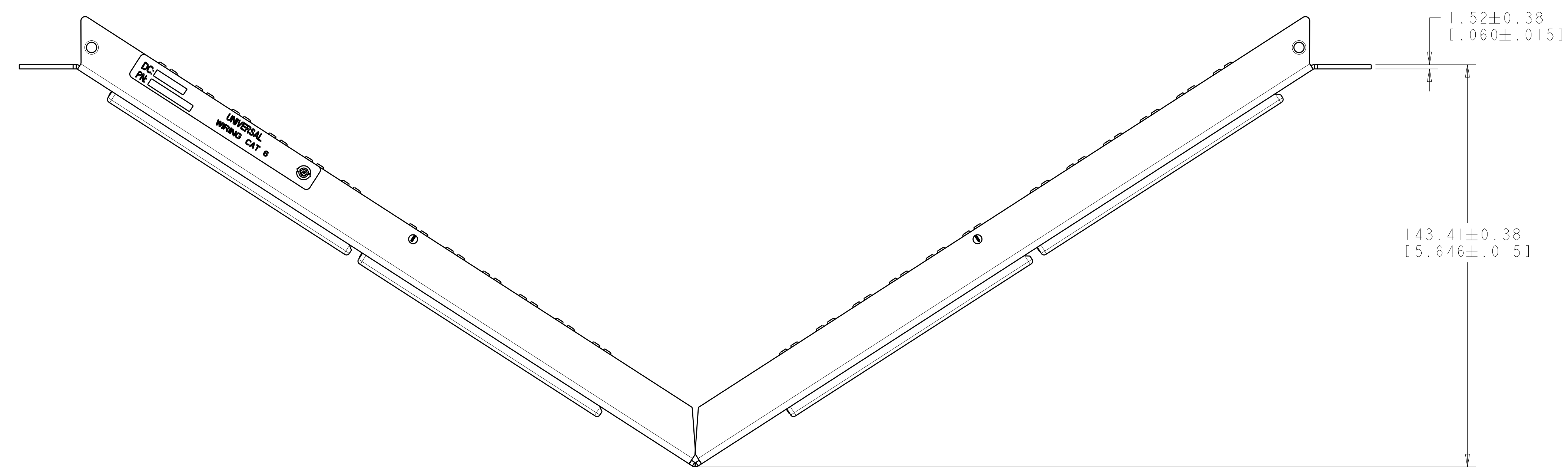

- △ MATERIAL:
 CONNECTOR HOUSING, INTERFACE: POLYESTER MOLDING COMPOUND, BLACK.
 PANEL: BLACK POWDER COAT STEEL WITH WHITE MARKINGS.
- FOUR BLACK 12-24 X 12.7 [1.500] LONG AND FOUR 10-32 X 12.7 [1.500] LONG CARBON STEEL CROSS RECESSED SCREWS FOR MOUNTING OF PANEL, SHIPPED LOOSE. NOT SHOWN ON DRAWING.
 - FOUR RELEASEABLE CABLE TIES USED FOR CABLE ORGANIZATION/ROUTING ARE SHIPPED LOOSE. NOT SHOWN ON DRAWING.
 - ONE BAG OF STRAIN RELIEFS SHIPPED LOOSE. NOT SHOWN ON DRAWING.
- △ JACKS PACKAGED AND SHIPPED LOOSE TO BE FIELD INSTALLED.

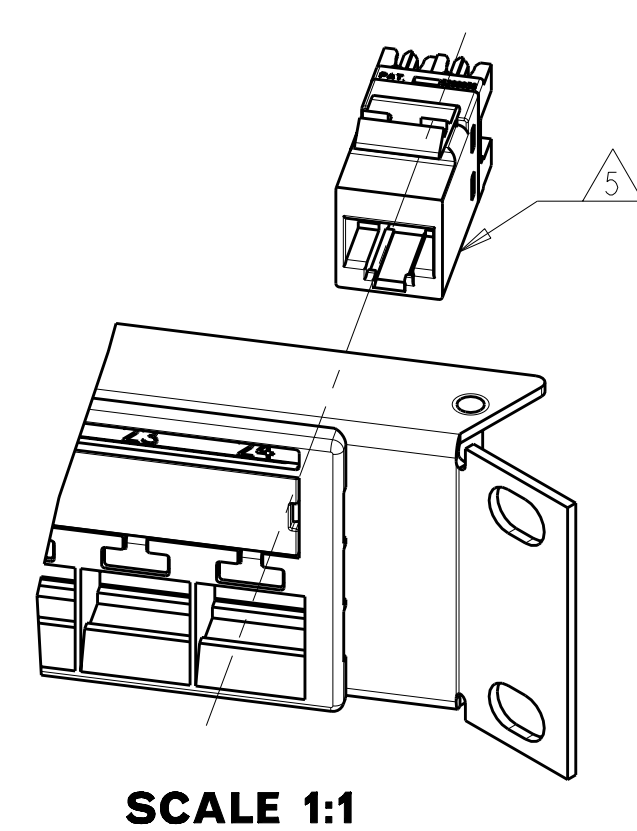
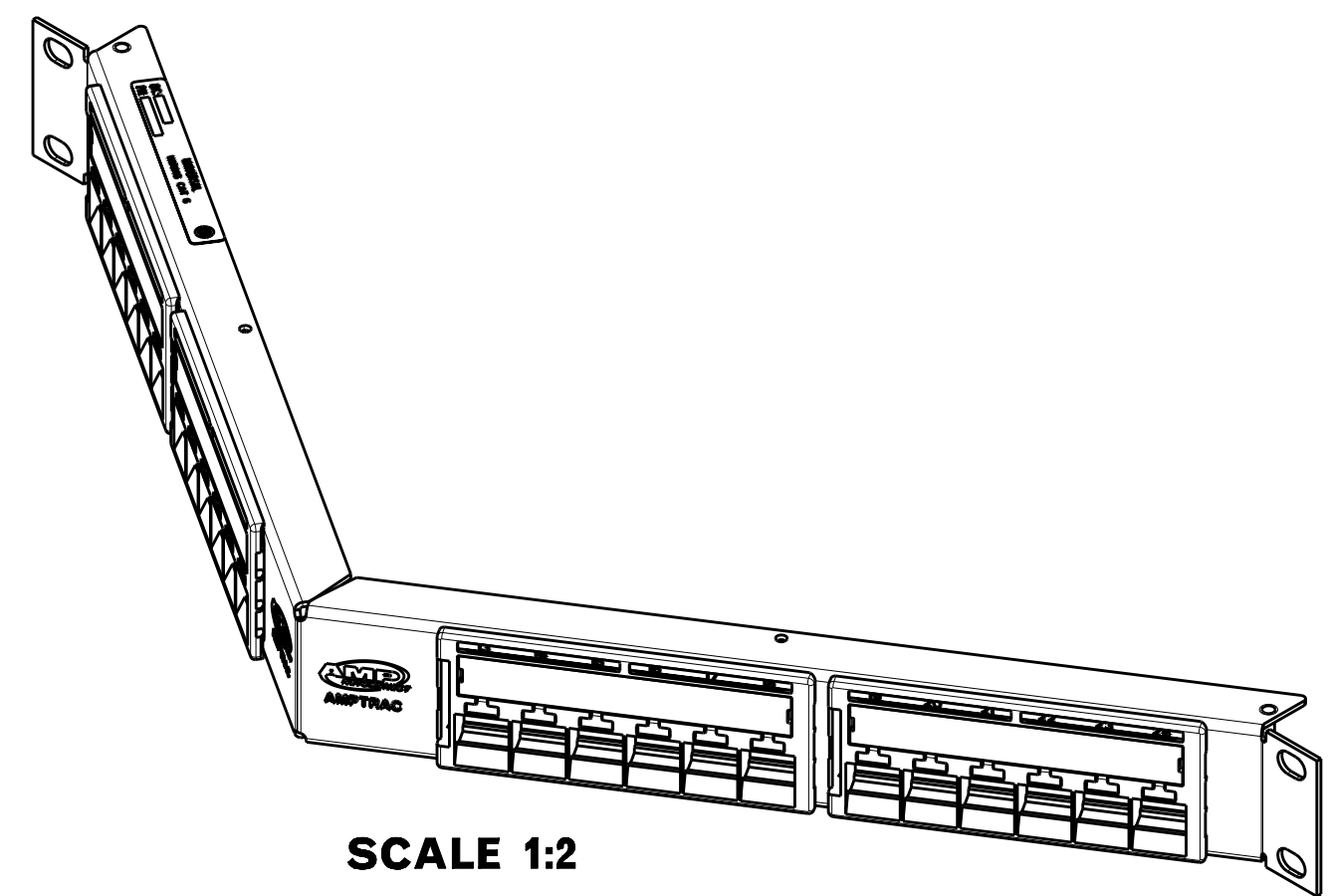
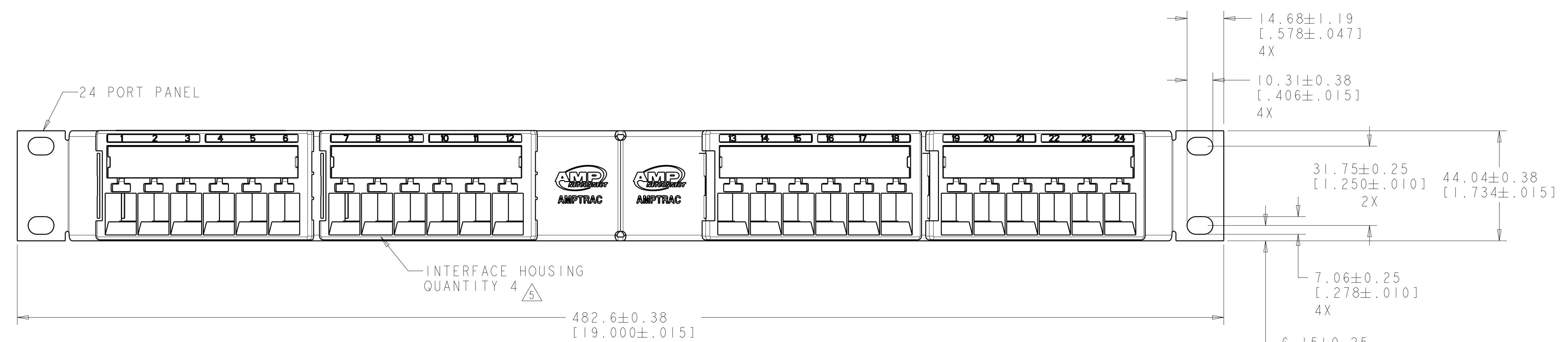

1933329-1
 PART NUMBER

DIMENSIONS: MME [INCHES]		TOLERANCES UNLESS OTHERWISE SPECIFIED: 9 PLC ±.015 1 PLC ±.010 3 PLC ±.005 4 PLC ±.002 ANGLES ±.010		DWN J MCNEAL 15MAY2007 CHK S HERNDON 15MAY2007 APVD S HERNDON 15MAY2007		Tyco Electronics Tyco Electronics Harrisburg, PA 17105-3608	
MATERIAL: △		FINISH: △		NAME: KIT, PATCH PANEL, AMPTRAC 1U, 24P, CAT6, ANGLED		SIZE: CAGE CODE DRAWING NO. RESTRICTED TO A 00779 C-1933329	
CUSTOMER DRAWING				SCALE: 1:2		SHEET 1 OF 1 REV C	